

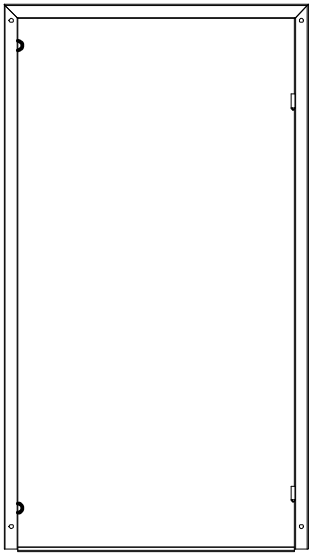

FRONTRAHMEN
1x A

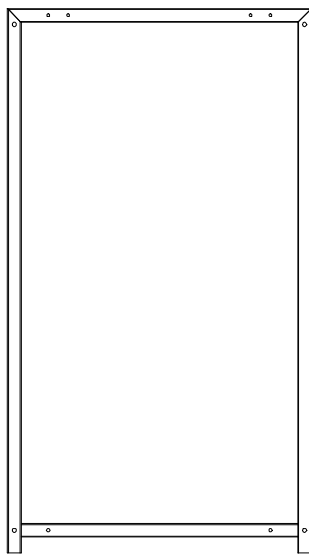

HINTERRAHMEN
1x B



VERBLENDUNG
4x B1

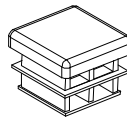

DECKEL
1x D

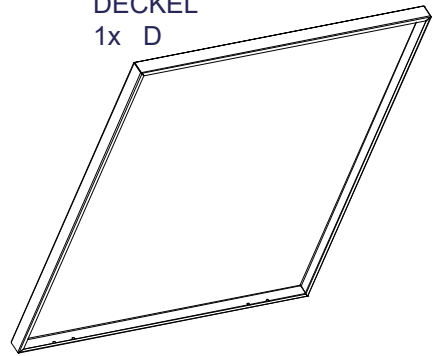

Bewehrung
DES DECKELS
RECHTS
1 x D1



Bewehrung
DES DECKELS
LINKS
1x D2



KETTE
2x D3



HINTERER BLECH 1x F

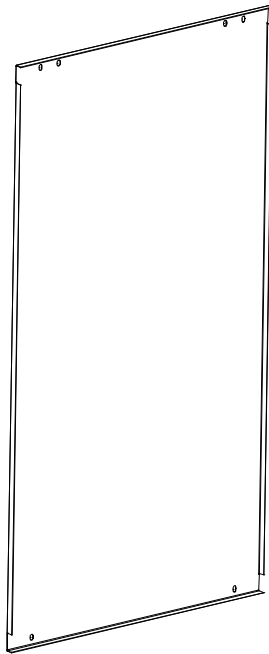

TÜR
1x G

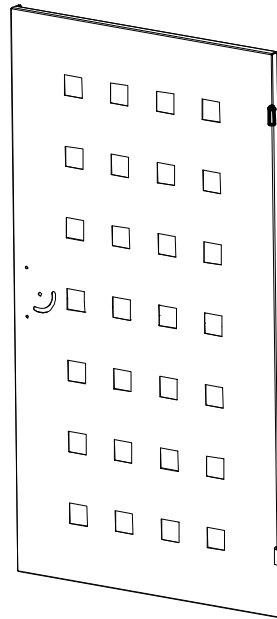

BOLZEN
DES SCHARNIERS
2x G1



Schraube
M5x16
2x D4



Unterlegscheibe 6
5x D5



Sicherungs-
Mutter M5
2x D6



GRIFF
2x H

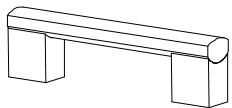

Schraube M6x16
1x J

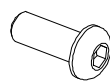

Schraube M6x40
2x K

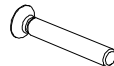

Schraube M6x70
3x K1

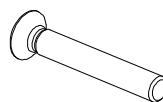

Schraube M6x80
1x K2

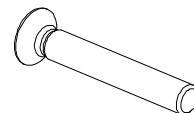

Sicherungsmutter
M6 7x L

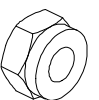

Schraube M4x12
4x H1

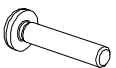

Unterlegscheibe 5
2x H2



Schraube
M4x10
4x N2



Sicherungsmutter
M4
8x N3



SICHERUNG DER
TÜR
1x O

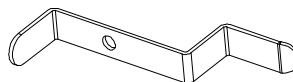

Schraube M8x50
8x M

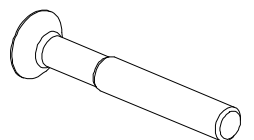

SCHARNIER
2x N

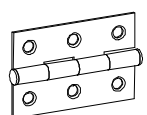

Schraube
M4x40
4x N1

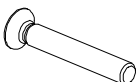

1.

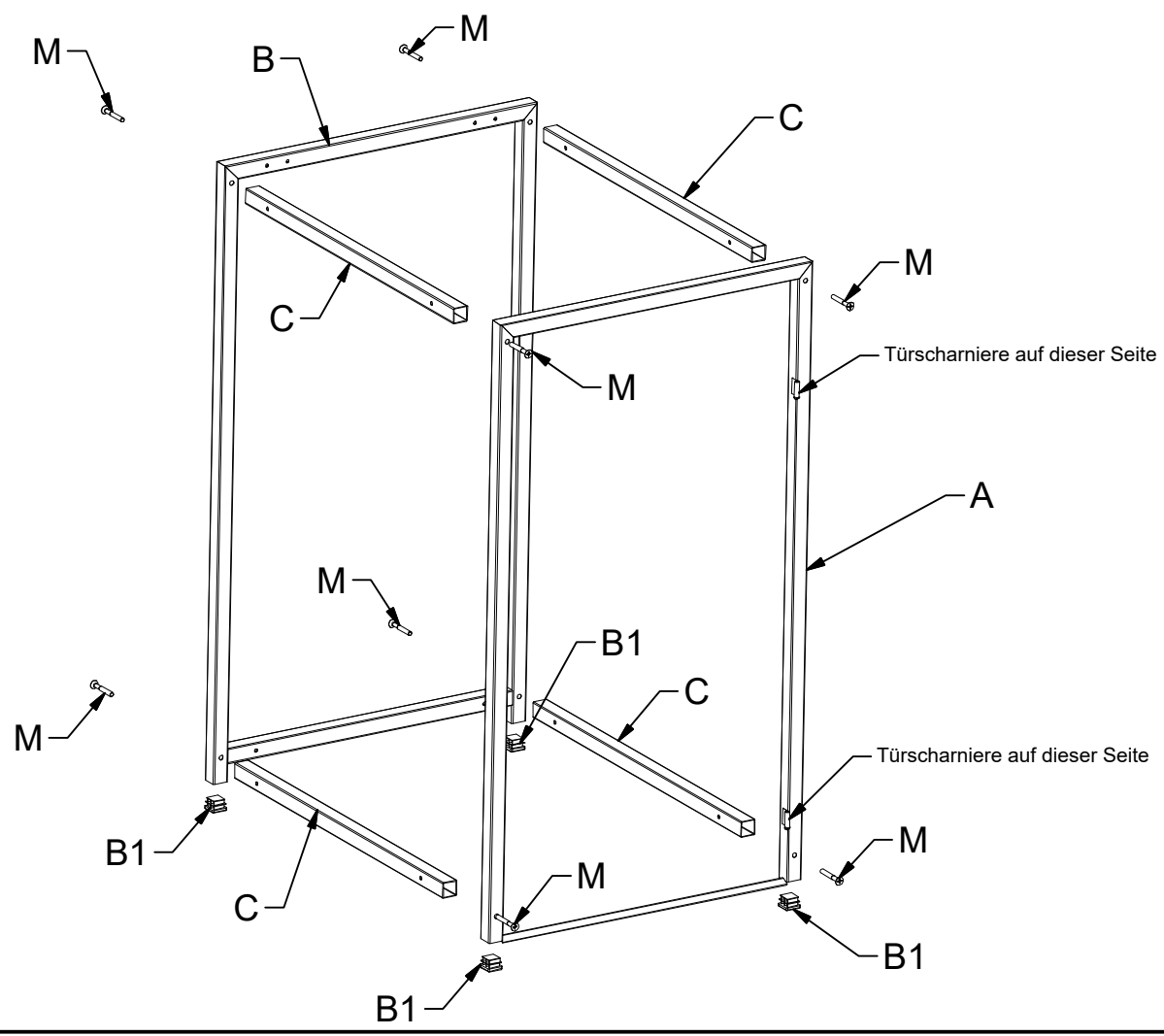

2.

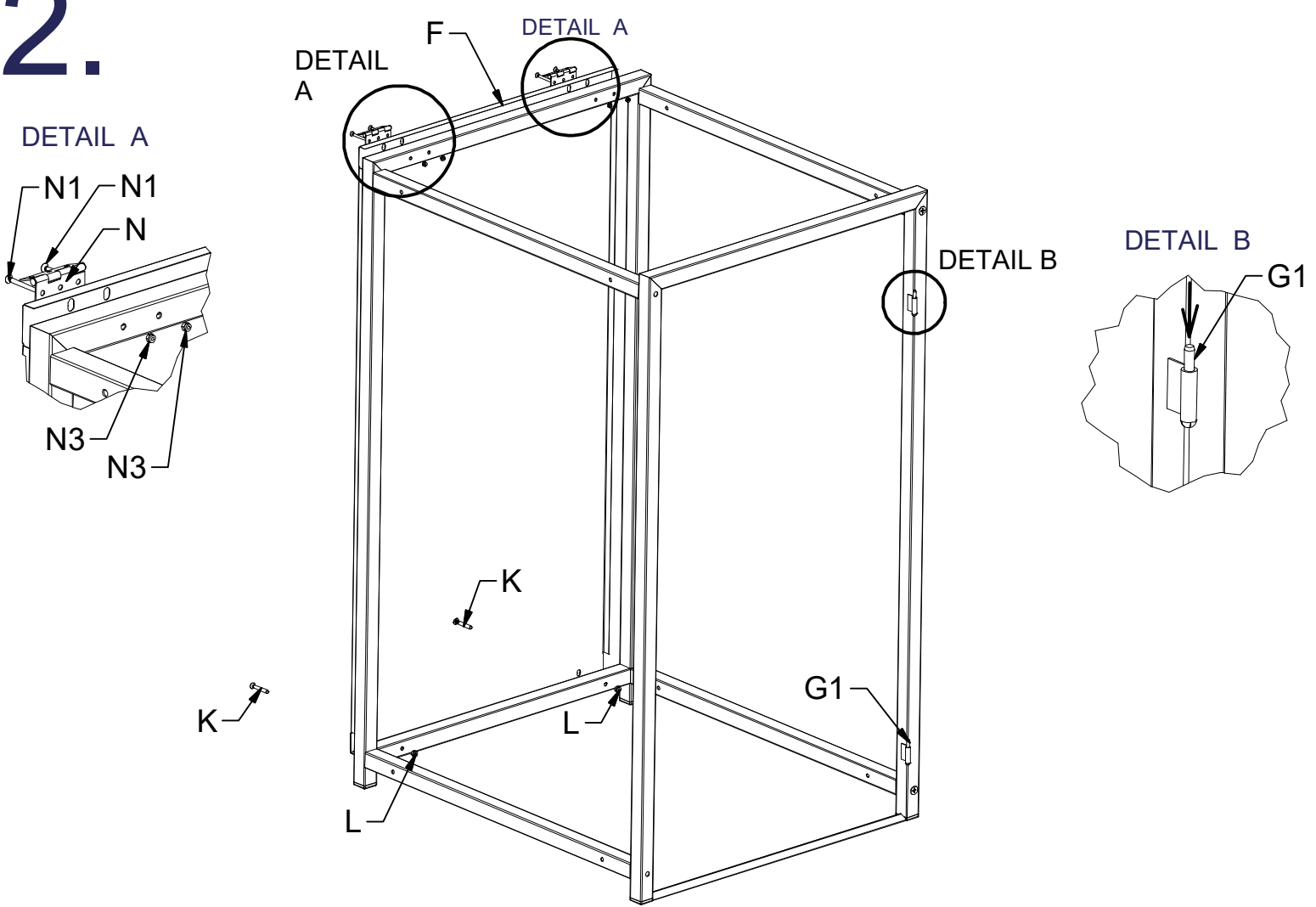

3.

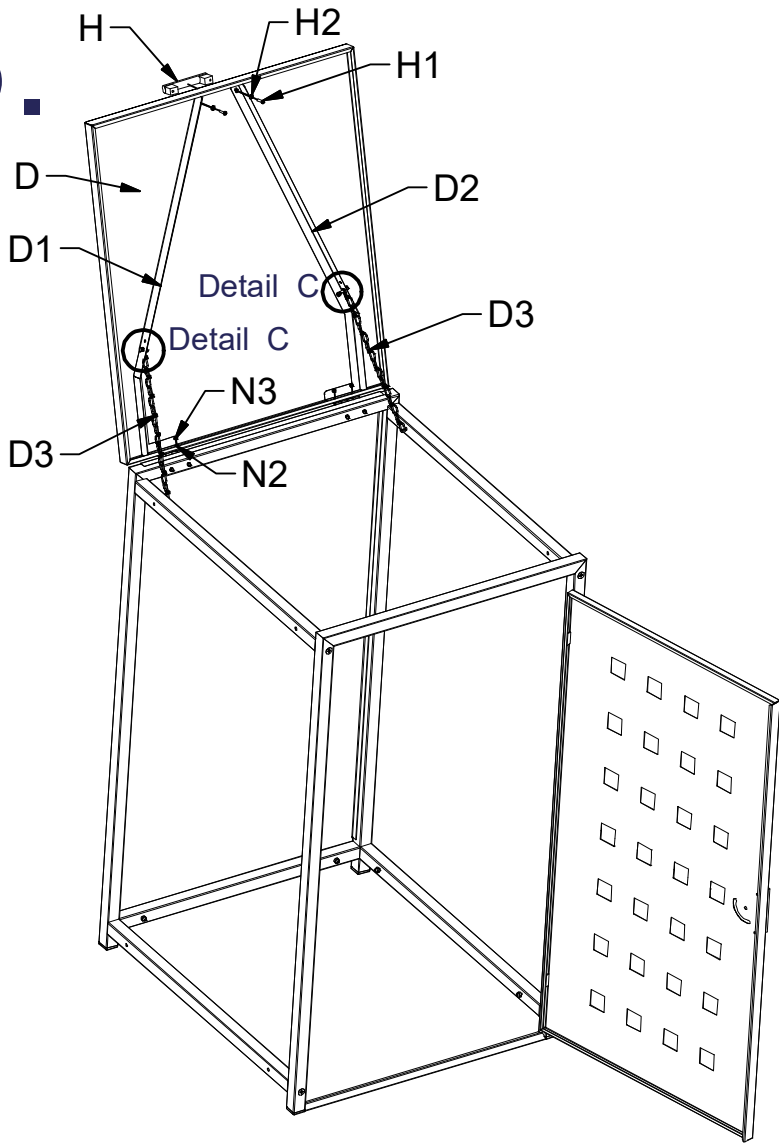

Detail C

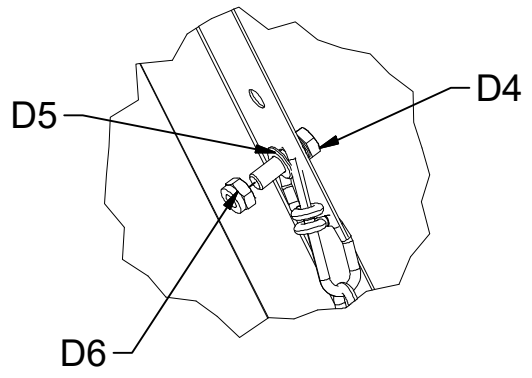

4.

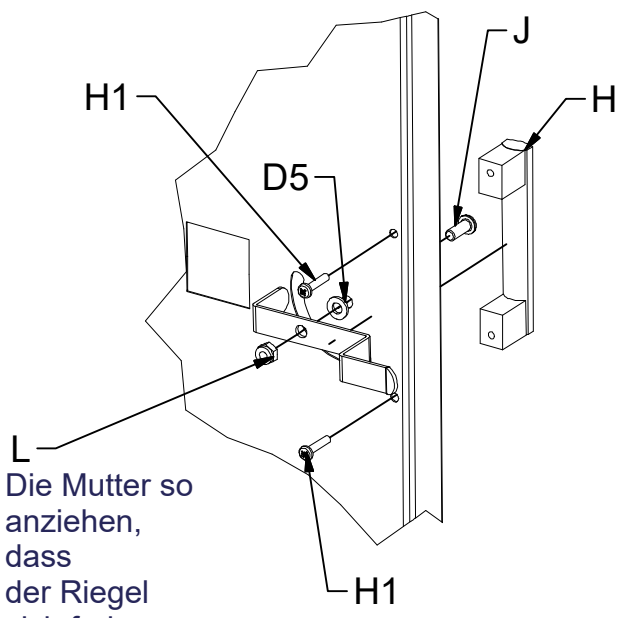

Die Mutter so anziehen, dass der Riegel sich frei drehen lässt.

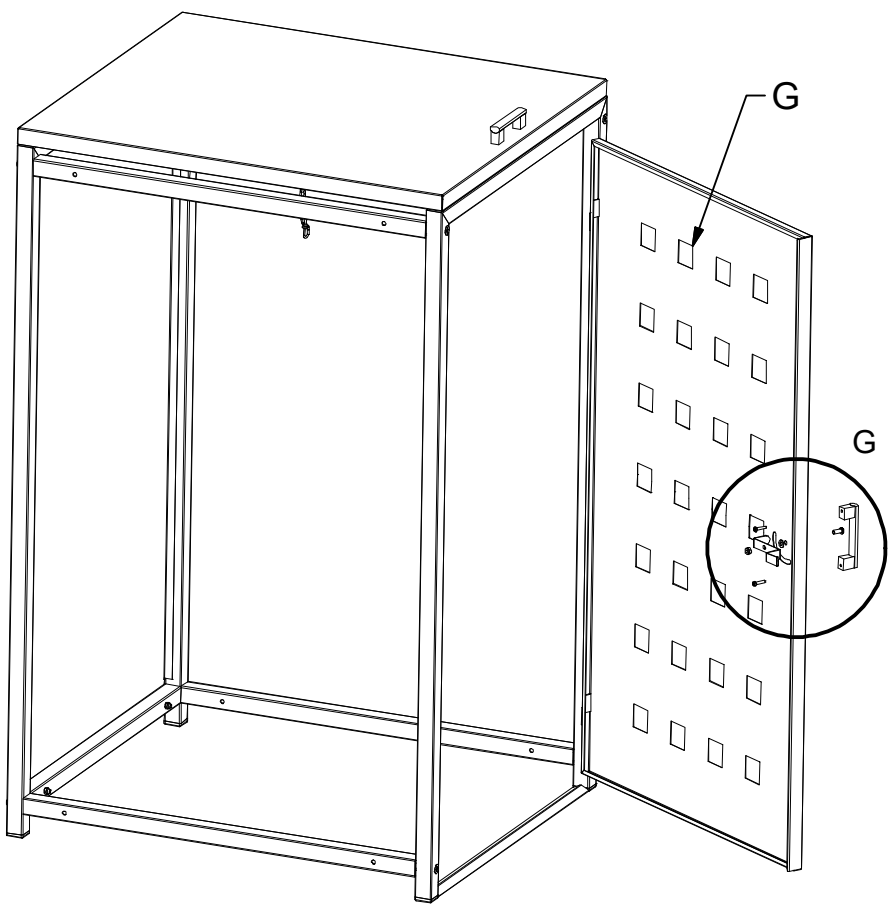

5.

